

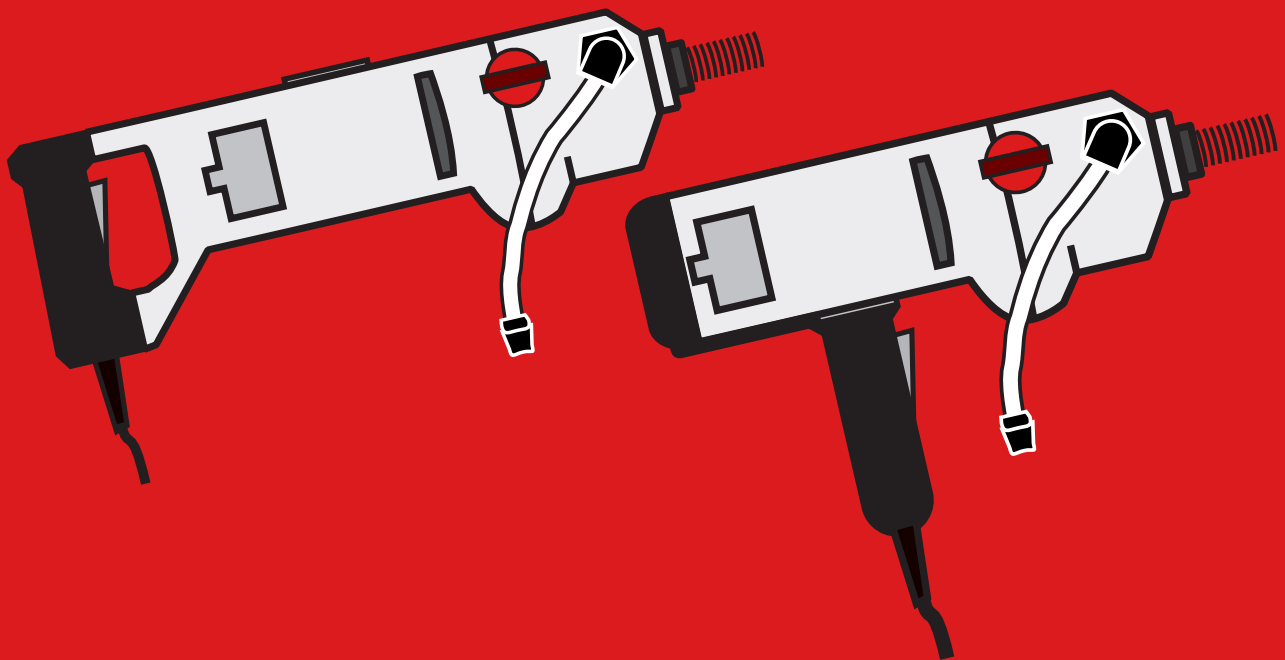

EN SAFETY AND USER MANUAL FOR:  
WET AND DRY USE HAND-HELD CORE DRILL

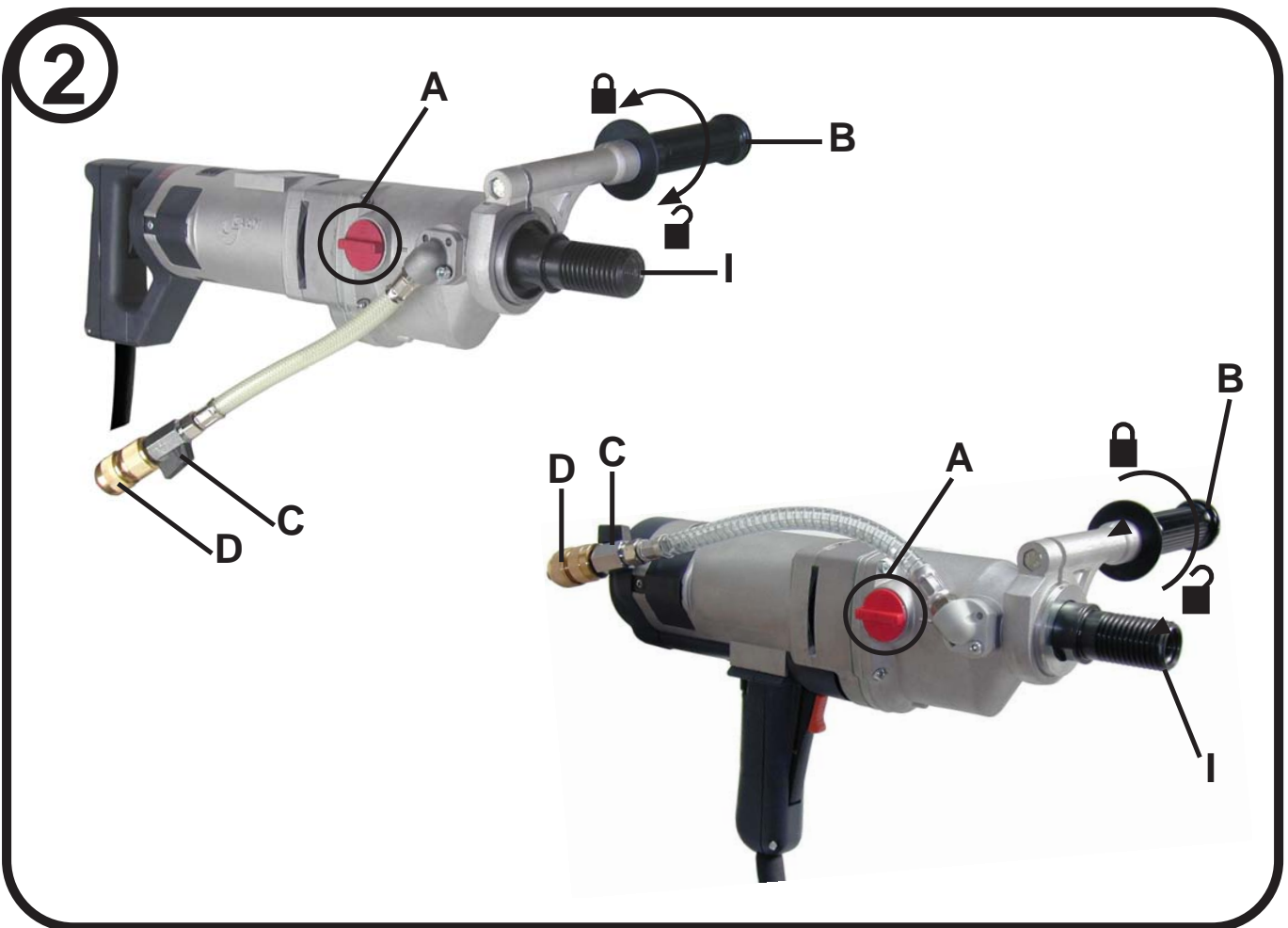

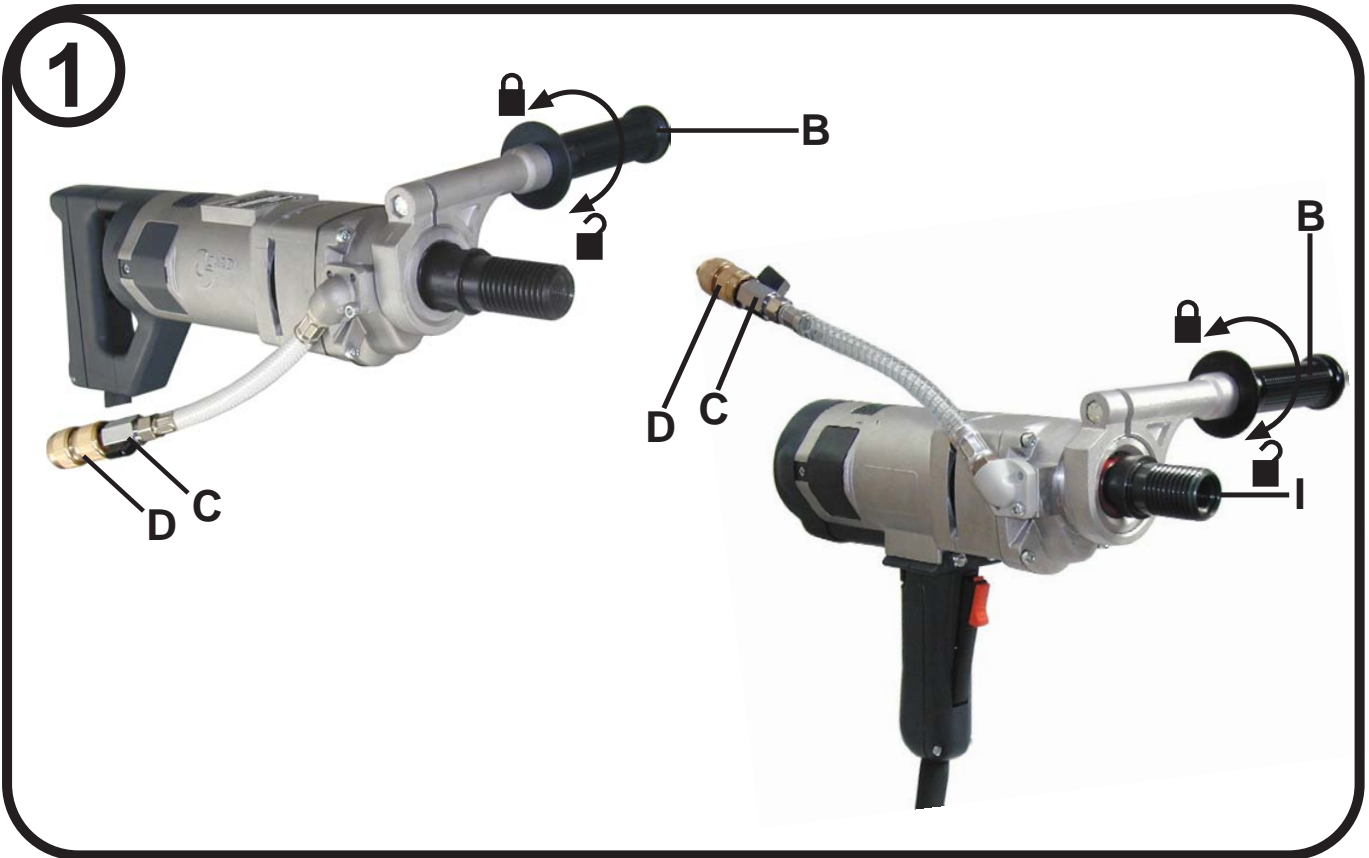

3

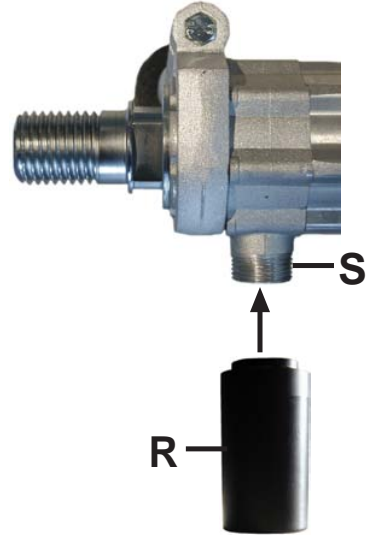
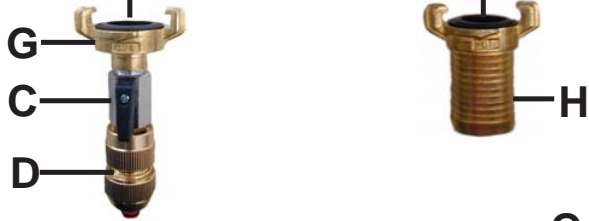
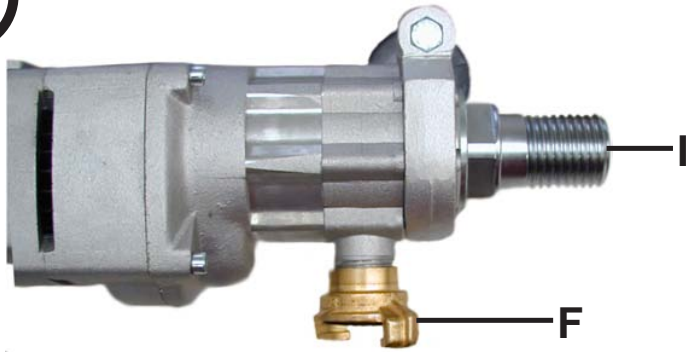

4

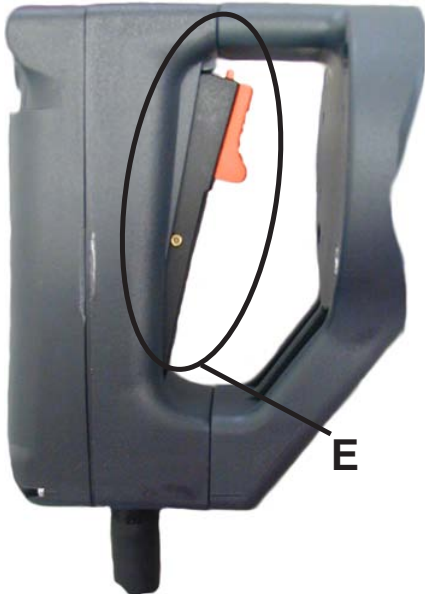

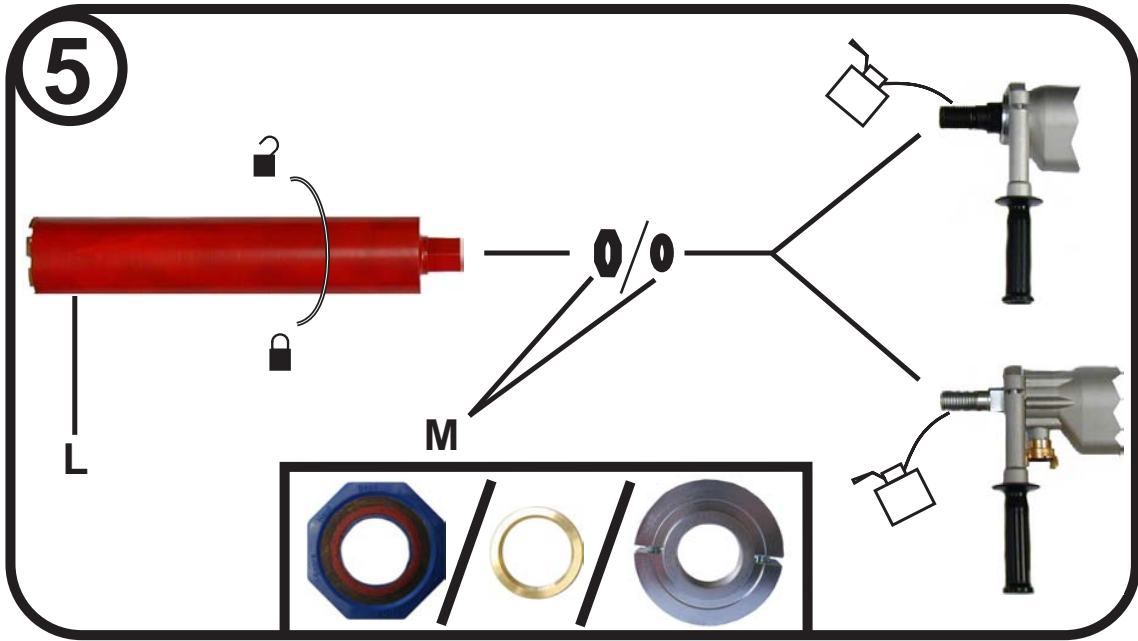

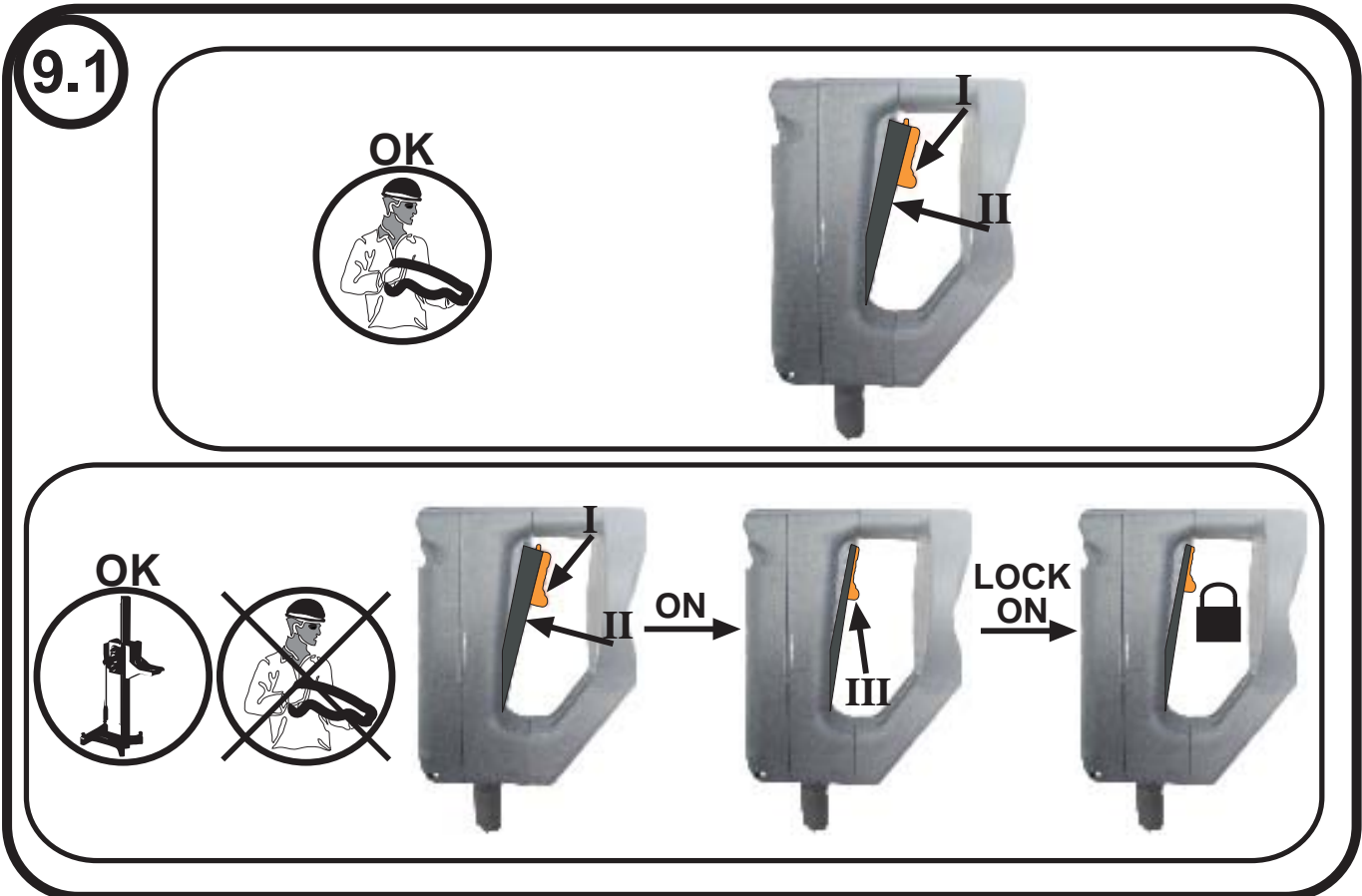
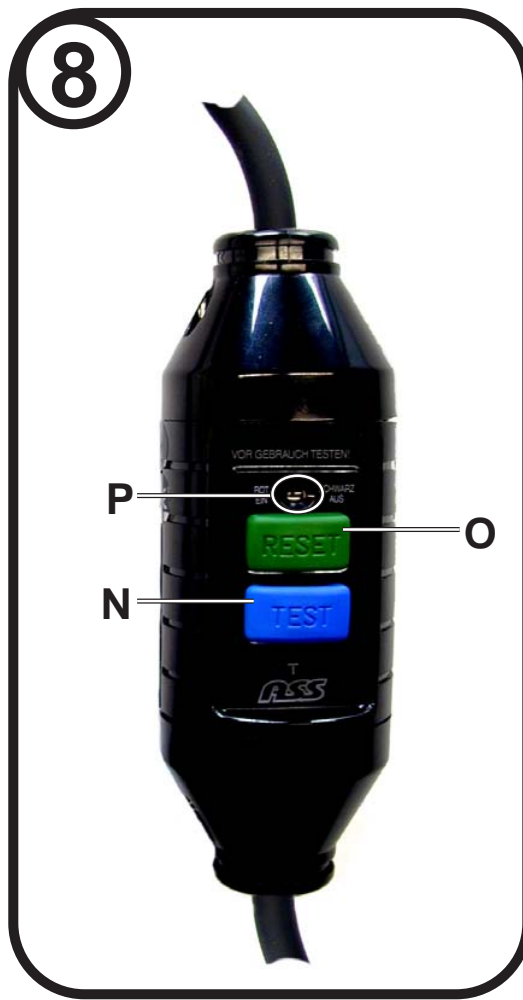

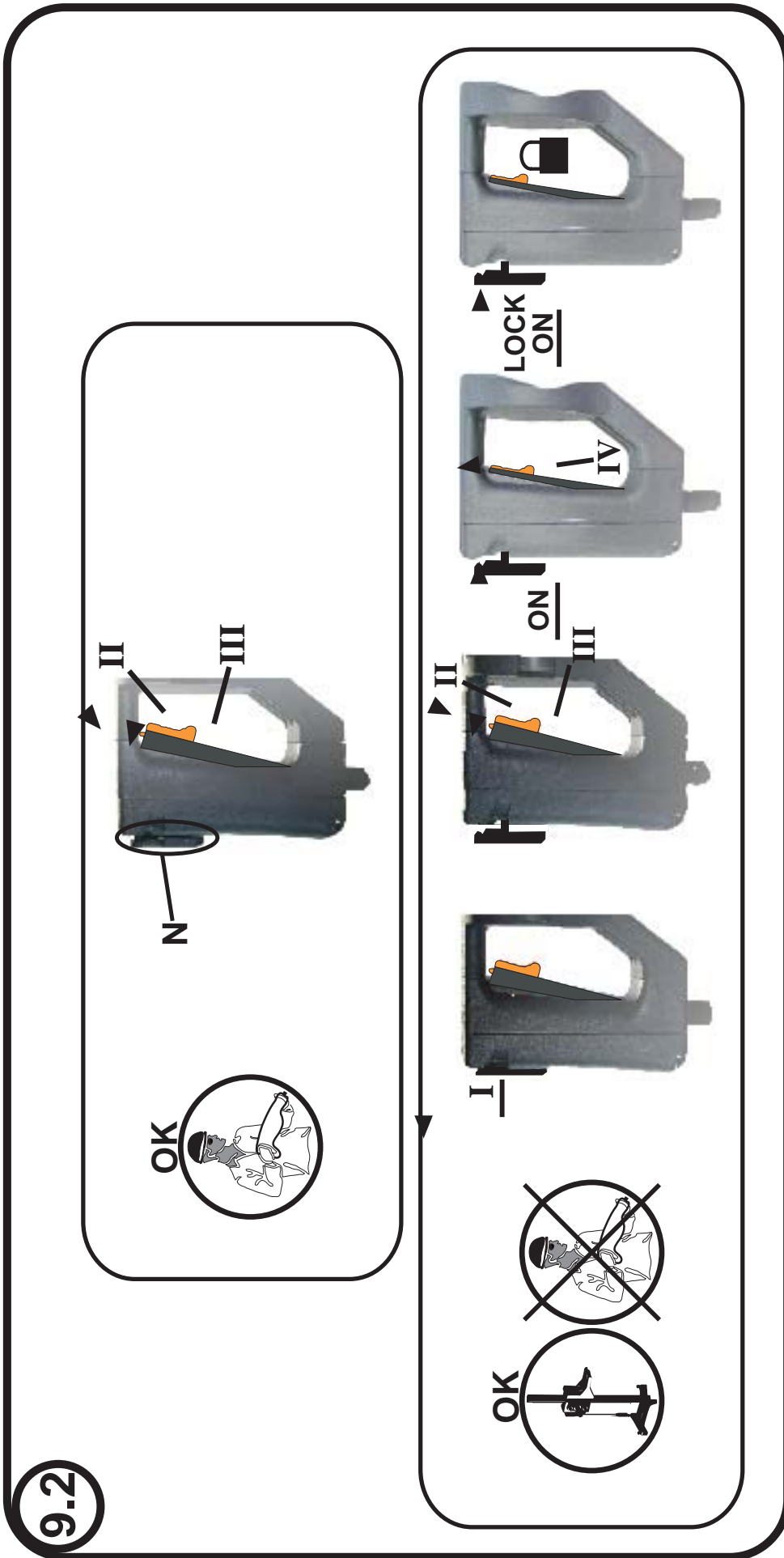

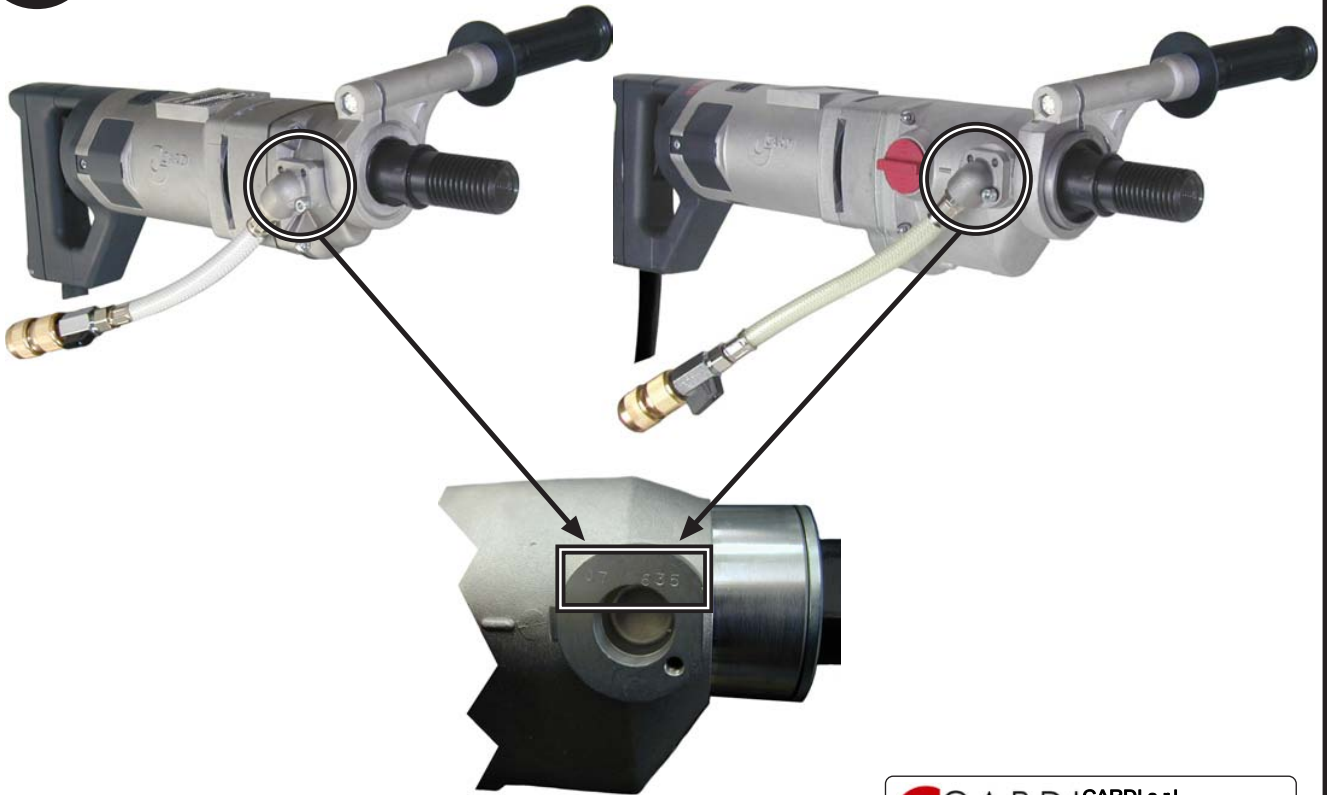

10





**CARDI** s.r.l.  
Via Leonardo Da Vinci, 21  
24030 - Pontida (BG) - Italy

**T1-MU-EL Serie A1**

2200 W | 230 V~ | 10 A | 50 + 60 Hz

	n <sub>0</sub> /min	n/min	 ø mm	 ø mm
I	750	530	250 + 190	150 + 90
II	1800	1280	190 + 150	90 + 50
III	2500	1780	150 + 90	50 + 20

Serial n.: |Matricola|

Made in E.U. 2008  

SERIAL #

SERIAL #



**SEZIONE MINIMA DEI CONDUTTORI PER CAVI DI PROLUNGA**  
**MINIMUM WIRE SIZE FOR EXTENSION CABLE**  
**MIN. ADERDURCHMESSER FÜR VERLÄNGERUNGSKABEL**  
**SECÇÃO MINIMA DE CABO**  
**EXTENSIÓN DEL CABLE**  
**SECTION DU CONDUCTEUR POUR CORDON PROLONGATEUR**  
**MINIMUM STØRRELSE PÅ FORLÆNGERKABEL**  
**ΕΛΑΧΙΣΤΟ ΜΕΤΕΩΣ ΑΓΩΓΩΝ ΓΙΑ ΚΑΛΩΔΙΑ ΠΡΟΕΚΤΑΣΗΣ**  
**MINIMALE DOORSNEDE ADERS VERLENGSNOER**

**AMPERE (A)**

**LUNGHEZZA - LENGTH - LÄNGE - LARGURA - LARGO**  
**LONGUEUR - LÆNGDE - ΜΗΚΟΣ - LENGTE**

<b>7,5 m</b>	<b>15 m</b>	<b>25 m</b>	<b>30 m</b>	<b>45 m</b>	<b>60 m</b>
<b>5,1 ÷ 7</b>	2,5 mm <sup>2</sup>	2,5 mm <sup>2</sup>	2,5 mm <sup>2</sup>	2,5 mm <sup>2</sup>	2,5 mm <sup>2</sup>
<b>7,1 ÷ 10</b>	2,5 mm <sup>2</sup>	2,5 mm <sup>2</sup>	2,5 mm <sup>2</sup>	2,5 mm <sup>2</sup>	4 mm <sup>2</sup>
<b>10,1 ÷ 16</b>	4 mm <sup>2</sup>	4 mm <sup>2</sup>	4 mm <sup>2</sup>	6 mm <sup>2</sup>	6 mm <sup>2</sup>
<b>16,1 ÷ 22</b>	4 mm <sup>2</sup>	4 mm <sup>2</sup>	6 mm <sup>2</sup>	6 mm <sup>2</sup>	-

3 CONDUTTORI (1 fase + 1 neutro + terra) per motori monofase 5 CONDUTTORI (3 fasi + 1 neutro + terra) per motori trifase	Caratteristiche dei cavi di prolunga: con 3 CABLES (2 polos+tierra) para motores mono-fase con 5 CABLES (3 polos+neutral+tierra) para motores tri-fase
---	--

Extension Cable: 3 WIRES (2 Pole + Ground ) for single phase motors. 5 WIRES (3 Pole + Ground + neutral ) for three phase motors.	Forlængerkabel: 3 LEDERE (2 poler + jord) for enkeltfaset motor 5 LEDERE (3 poler + jord + neutral) for trefaset motor.
---	---

Vergrößerungskabel: 3 ADRIEG (2 Pole + Erde) für Einphasenmotoren 5 ADRIEG (3 Pole + Nullleiter + Erde) für Dreiphasenmotoren	Καλώδια προέκτασης: 3 ΑΓΩΓΟΙ (2 πόλοι + γείωση) για μονοφασικούς κινητήρες 5 ΑΓΩΓΟΙ (3 πόλοι + γείωση + ουδέτερος) για τριφασικούς κινητήρες
---	--

Caracteristicas dos cabos: Com 3 CABOS (2 polos + terra) para motores mono-fasicos. Com 5 CABOS (3 polos + neutro + terra) para motores tri-fasicos.	Verlengsnoer: 3-aderig (2 polen plus aarde) voor eenfasemotoren 5-aderig (3 polen plus aarde plus neutral) voor driefasemotoren
--	---

Le cordon prolongateur doit être : 3 CONDUCTEUR (2 Pole + Terre ) pour moteurs monophasés. 5 CONDUCTEUR (3 Pole + Terre + neutral ) pour moteurs triphasés.	
---	--



12

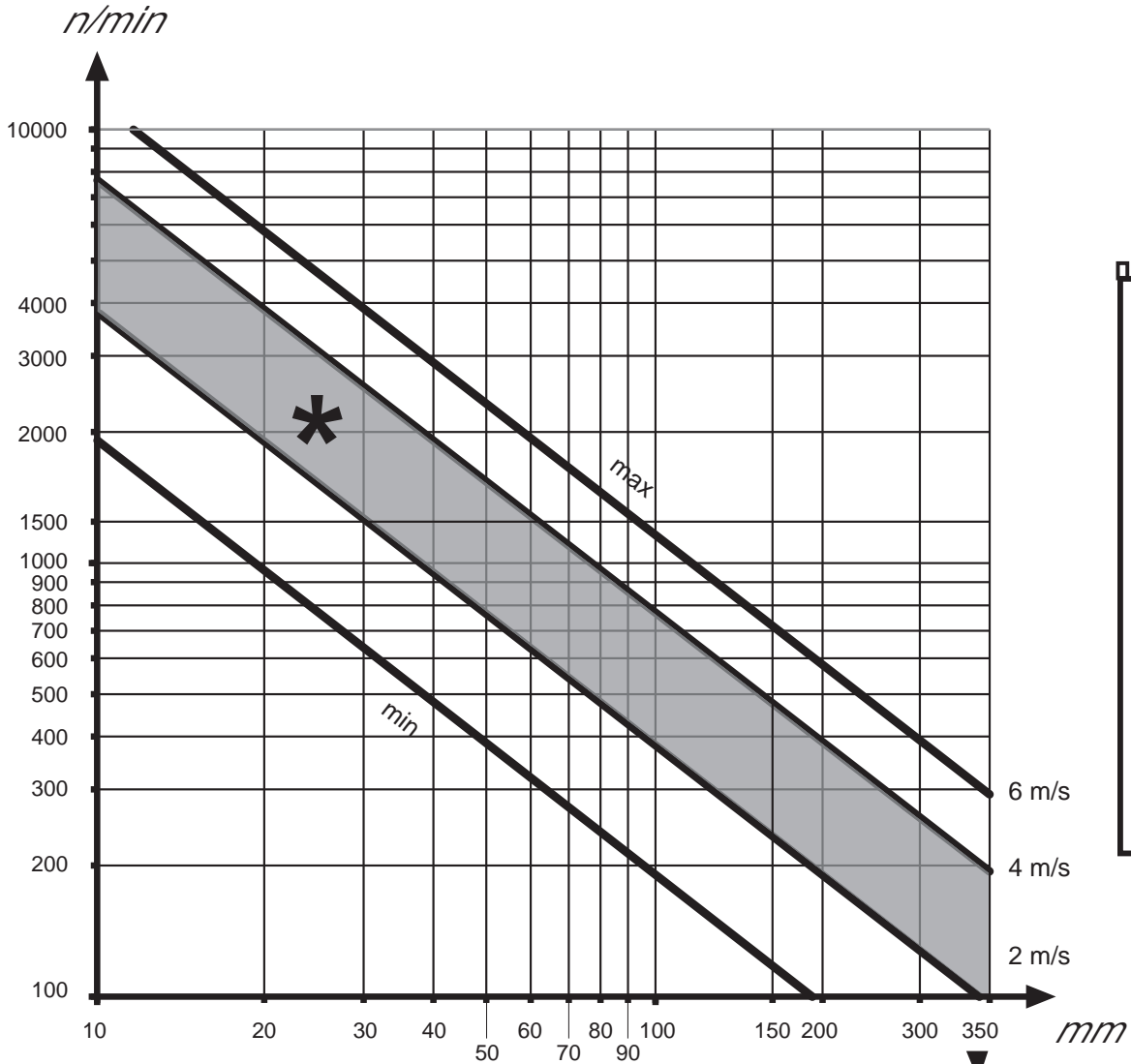

  
**VELOCITA' IDEALE**  
**OPTIMAL SPEED**  
**EMPFOHLENE U/min**  
**VELOCIDAD IDEAL**  
**VITESSE IDEALE**  
**VELOCIDADE IDEAL**  
**IDEELLE HASTIGHED**  
**ΒΕΛΤΙΣΤΕΣ ΣΤΡΟΦΕΣ**  
**OPTIMALE SNELHEID**

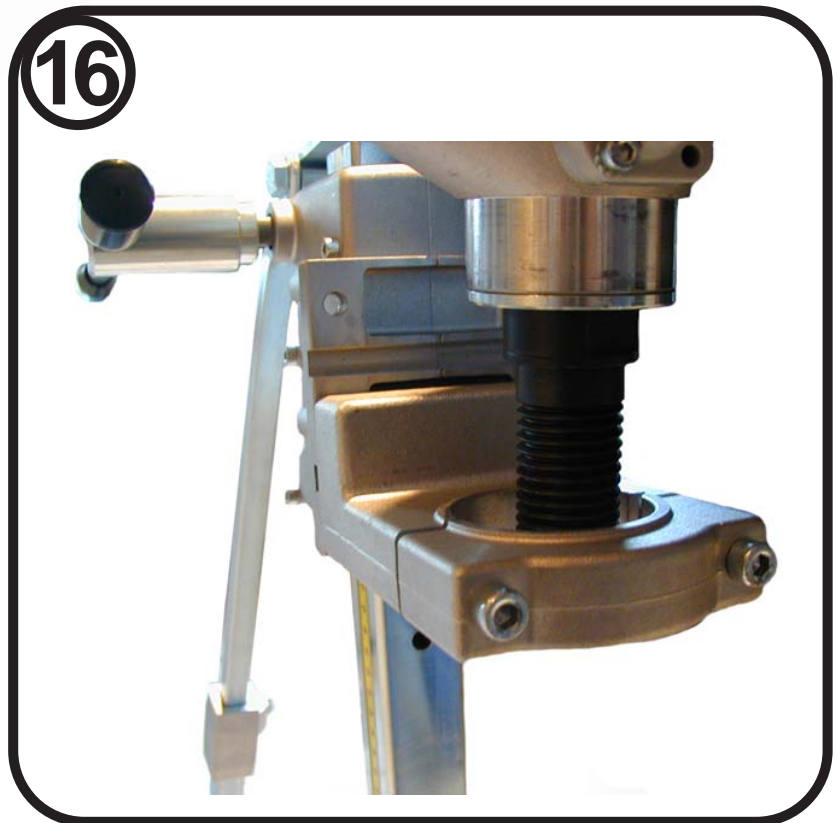
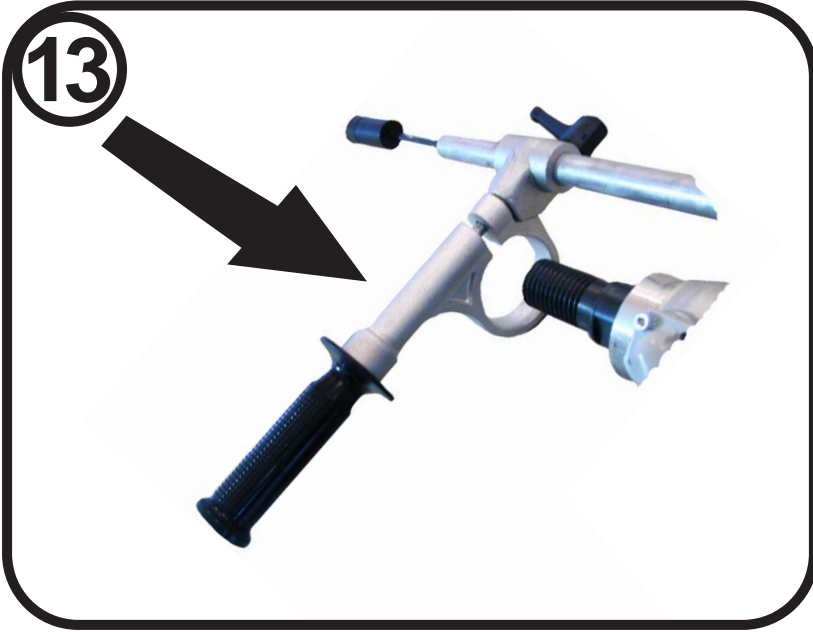

Your CARDI core drill is a power tool designed to make holes in stone-like materials (ex: bricks, masonry, natural stone) using diamond core bits. It can be used hand-held or with a proper drill stand.

## General safety rules

**WARNING!** Read all instructions. Failure to follow all instructions listed below may result in electric shock, fire and/or serious injury. The term "power tool" in all of the warnings listed below refers to your mains operated (corded) power tool or battery operated (cordless) powertool.

### SAVE THESE INSTRUCTIONS

#### 1) Work area

- a) **Keep working area clean and well lit.** Cluttered and dark areas invite accidents.
- b) **Do not operate power tools in explosive atmospheres, such as in the presence of flammable liquids, gases or dust.** Power tools create sparks which may ignite the dust or fumes.
- c) **Keep children and bystanders away while operating a power tool.** Distractions can cause you to lose control.

#### 2) Electrical safety

- d) **Power tool plugs must match the outlet. Never modify the plug in any way.** Do not use any adapter plugs with earthed (grounded) power tools. Unmodified plugs and matching outlets will reduce risk of electric shock.
- e) **Avoid body contact with earthed or grounded surfaces such as pipes, radiators, ranges and refrigerators.** There is an increased risk of electric shock if your body is earthed or grounded.
- f) **Do not expose power tools to rain or wet conditions.** Water entering a power tool will increase the risk of electric shock.
- g) **Do not abuse the cord. Never use the cord for carrying, pulling or unplugging the power tool. Keep cord away from heat, oil, sharp edges or moving parts.** Damaged or entangled cords increase the risk of electric shock.
- h) **When operating a power tool outdoors, use an extension cord suitable for outdoor use.** Use of a cord suitable for outdoor use reduces the risk of electric shock.

#### 3) Personal safety

- a) **Stay alert, watch what you are doing and use common sense when operating a power tool. Do not use a power tool while you are tired or under the influence of drugs, alcohol or medication.** A moment of inattention while operating power tools may result in serious personal injury.
- b) **Use safety equipments: always wear eye protection.** Safety equipment such as dust mask, non-skid safety shoes, hard hat, or hearing protection used for appropriate conditions will reduce personal injuries.
- c) **Avoid accidental starting. Ensure the switch is in the off position before plugging in.** Carrying power tools with your finger on the switch or plugging in

power tools that have the switch on invites accidents.

- d) **Remove any adjusting key or wrench before turning the power tool on.** A wrench or a key left attached to a rotating part of the power tool may result in personal injury.
- e) **Do not overreach. Keep proper footing and balance at all times.** This enables better control of the power tool in unexpected situations.
- f) **Dress properly. Do not wear loose clothing or jewellery. Keep your hair, clothing and gloves away from moving parts.** Loose clothes, jewellery and long hair can be caught in moving parts.
- g) **If devices are provided for the connection of dust extraction and collection facilities, ensure these are connected and properly used.** Use of these devices can reduce dust related hazards.
- h) **Use auxiliary handles supplied with the tool.** Loss of control can cause personal injury.

#### 4) Power tool use and care

- a) **Do not force the power tool. Use the correct power tool for your application.** The correct power tool will do the job better and safer at the rate for which it was designed.
- b) **Do not use the power tool if the switch does not turn it on and off.** Any power tool that cannot be controlled with the switch is dangerous and must be repaired.
- c) **Disconnect the plug from the power source before making any adjustments, changing accessories, or storing power tools.** Such preventive safety measures reduce the risk of starting the power tool accidentally.
- d) **Store idle power tools out of the reach of children and do not allow persons unfamiliar with the power tool or these instructions to operate the power tool.** Power tools are dangerous in the hands of untrained users.
- e) **Maintain power tools. Check for misalignment or binding of moving parts, breakage of parts and any other condition that may affect the power tools operation.** If damaged, have the power tool repaired before use. Many accidents are caused by poorly maintained power tools.
- f) **Keep cutting tools sharp and clean.** Properly maintained cutting tools with sharp cutting edges are less likely to bind and are easier to control.
- g) **Use the power tool, accessories and tool bits etc., in accordance with these instructions and in the manner intended for the particular type of power tool, taking into account the working conditions and the work to be performed.** Use of the power tool for operations different from intended could result in a hazardous situation.

#### 5) Service

- h) **Have your power tool serviced by a qualified repair person using only identical replacement parts.** This will ensure that the safety of the power tool is maintained.

**Additional safety rules for diamond core drills**

Always wear safety goggles



Always wear safety gloves



Always wear ear protection



Always wear safety shoes



Always wear dust mask

**Instructions before use**

Read carefully the data reported on the data plate of your core drill and on the *Technical Data* sheet that you will find in the package together with your product.

In the following text, figures are identified by numbers, details inside the figures by letters. Figures are depicted on the first pages of this user manual.

**Drilling technique choice**

Choose one of the following drilling techniques according to the material you want to drill and according to the diameter and the length of the hole you want to make.

**a) Hand-held dry drilling**

- this technique is suitable for drilling into abrasive materials like tiles, gasbeton, poroton, etc;
- this technique is not suitable when you want to make holes into concrete (reinforced or not reinforced);
- dry drilling is more effective and safe if dust is removed by an industrial vacuum cleaner. In particular you must remove the dust if you drill vertically downwards;
- if you want to remove the dust with an industrial vacuum cleaner, make sure that your core drill is equipped with the dust extraction integrated device (see figure 3, components F and H) that allows you to connect your core drill to an industrial vacuum cleaner. Otherwise use a proper accessory, called dust extraction device (Q), that can be mounted to the front part of the core drill;
- the industrial vacuum cleaner must be suitable for thin dust;
- always wear a dust mask when performing dry drilling.

**b) Hand-held wet drilling**

- wet drilling means that you drill with water coming out of the core bit removing the drilling dust. The water comes into the core drill through a hosepipe connection;
- this technique is suitable for holes into compact and hard materials like concrete (reinforced or not reinforced), bricks, stone, stone-like materials etc. when the diameter of the hole is below 80 mm and depth below 400 mm;
- if your core drill has a maximum drilling diameter below 80 mm, follow this value;

**c) Drilling with a drill stand**

- this drilling technique is safer and more effective than the hand-held drilling technique;
- this technique is suitable when you want to make holes with diameter below the maximum drilling diameter reported on your product, into any kind of material. In particular you must use a drill stand if you are drilling outside the limits defined before for hand-held drilling, in terms of material and diameter.



when you use your core drill mounted to a stand, follow the directions given by the stand manufacturer;

**Power supply****Earth (Ground)**

- the metallic parts of your core drill are connected to the earth.
- make sure that the socket and possible extension cords and multiple sockets have the earth connection and that your electrical system is properly connected to the earth.



**Warning:** for your safety, it is important that the whole system (electrical system, extension cords, sockets etc.) is connected to the earth. If you are not sure, ask a qualified electrician for a check.

**Extension cords**

- when you have to operate with your core drill far from an electrical socket, you can use an extension cord. If you use it make sure that the section of the cord is suitable and that the cord is provided with ground conductor;
- the extension cord (made up of cable, plug and socket) must be suitable for outdoor use. It is better if the cord is made of rubber and it is H07RN-F;
- follow the chart shown in figure 11 on this manual for the choice of the right section of the conductors;
- if you use more than one extension cord make sure that every cable in each extension cord has a section not lower than the value shown on the chart in figure 11, considering the total length of the extension cords;
- remember that the more an extension cord is long the more the voltage drop is high and the worse is the operation of your core drill. Don't use extension cords if you have to operate too far from the electrical socket.

**PRCD: portable residual current device (GFI)**

- your core drill is equipped with a safety portable residual current device (PRCD) assembled on the cord. This device is shown in figure 8;
- never use core drill without PRCD;
- before starting to drill make sure the PRCD works properly. In order to do so, plug the core drill in and press the green button Reset (O): a red led will light up (P) showing that electricity is available to the core drill. Then press the blue button Test (N) that tests if the device works properly. When you press it the circuit breaker inside the PRCD should cut the power off leading the switch automatically to go to the off position and the red led to go off;
- if, when drilling, the PRCD cuts the power: stop working, set the main switch of you core drill on the OFF position and bring your core drill to an authorized service centre in order to remove the causes of the electrical dissipation.

**Preliminary operations**

In order to prepare your core drill to operate, follow these steps. Before proceeding with the preparation make sure that the plug is disconnected from the outlet.

1. If you use your core drill manually, fix the auxiliary handle (B) to the core drill, as shown in figures 1 and 2.





**Warning:** If you don't use the auxiliary handle you can lose control of the core drill and this can lead to serious personal injuries.

If you use your core drill with a stand, fix the machine into the collar of the stand as shown in figure 16.



Follow instructions given by the stand manufacturer to fix the stand to the material you want to drill.

b) Follow these instructions:

- if you want to operate in wet mode, connect the hosepipe to the core drill as explained in the following *Water insertion* paragraph. Make sure that the water valve is shut.
- if your core drill is equipped with a gear change (figure 2 A), see the data plate on your core drill as shown in figure 12. Identify the right rotating speed according to the diameter of the core bit you are using and the material you are drilling. The symbol  refers to abrasive materials (like tiles, gasbeton, poroton...), the symbol  refers to hard materials (like reinforced concrete...). Select the required gear change position just when the motor is at standstill;
- refer to the following paragraph *Diamond core bit mounting and replacement* in order to mount the core bit to your core drill.

## ON/OFF switch

See figure 9.1 and 9.2 in order to understand how to use the switch;

- the main switch of your core drill machine is equipped with a block (lock-on) device that blocks the switch in the *on* position.



**Warning:** this device can be used ONLY when the machine is fixed to a proper stand. You must not use the block device when you are using your core drill hand-held;

- your switch can be equipped with a safety *anti lock-on device* (N), shown in figure 9.2, that doesn't allow you to use the block device when the core drill is used hand-held.



**Warning:** for your safety, you must get familiar with the switch in order to prevent the unintentional switching on of the core drill.

## Connection to a water supply

Wet drilling needs the insertion of water into the core drill. This can be done in two ways: by using the water insertion system shown in figure 2 or by using the combined system shown in figure 3. During wet drilling follow these instructions:

- use just the water insertion systems provided with your machine, depicted in figure 1, 2 or 3. The water systems include a valve (C) and a quick hose connector (D);
- the maximum pressure allowed of the incoming water is 4 bar;
- use just clean water;
- make sure that the water doesn't come into contact with any electric part of your core drill;
- check regularly that none of the water system components are damaged. Check in particular the valve (C), the quick hose connector (D) and, alternatively, the connectors (F and G) or the pipe and the elbow connector.

## Combined dust extraction and water insertion system

Your core drill can be equipped with a combined dust extraction and water insertion system integrated into the machine, shown in figure 3. You can use this system to insert water or, alternatively, to extract dust using an industrial vacuum cleaner. The following instructions show you how to use this system in the these two modes.

### Water insertion

- mount the quick hose connector (D) to the hosepipe, making sure that the valve is shut (perpendicular to the water stream);
- join the connector G to the connector F mounted to the core drill. Make sure that the two connectors are firmly joined;

### Dust extraction

- connect a proper industrial vacuum cleaner to the pipe connection device (H). The vacuum cleaner must be suitable to suck thin dust up;
- connect the pipe connection device to the quick connection device (F).

As an alternative, you can use a special accessory (R).

## Checks and precautions to avoid structural damage and damage to the plant

Before starting any drilling activity, talk with the construction manager or the planner in order to make sure that the drilling doesn't:

- make any damage to the structure of the building and doesn't change the structural characteristics of the construction;
- damage any water or gas pipeline or any electric mains.

## Checks and precautions to avoid damage caused by the fall of the core

- before drilling, make sure that the possible falling out of core from the other side of the hole doesn't make any damage. Always bound the area where the core can fall and signal the danger;
- if the possible fall of the core can make damage, make a system that holds the core when drilling is completed.

## Start drilling device

When you use your core drill hand-held, you must use a *start drilling device*. Some examples are shown in figures 13, 14 and 15. This devices allow safe and precise drilling.



**Warning:** not using these devices can lead to excessive arms vibration.

## Core bit choice

The maximum and minimum core bit diameter, according to the kind of drilling performed, is reported on the data plate on your core drill. Pay attention to further limitation to the core bit diameter reported in the paragraph *Drilling technique choice*.



**Warning:** for your safety do not use different core bits from the ones prescribed for your specific application.

The core bit is different depending on the material to be drilled and the kind of drilling you are performing: consult your dealer about the correct core bit for your application. The not suited core bit or a core bit not sharp can overload the motor leading to damage to the motor, long drilling time, excessive diamond segments wear.

## Diamond core bit mounting and replacement

Follow these directions, refer to figure 5:

- before mounting or removing the core bit (L) always unplug the core drill;
- lubricate the core bit and the core bit spindle thread in order to make easier, after use, the core bit removal;
- if your core bit connection doesn't match the core bit spindle (ex. 1/2 G), use a proper adapter available among CARDI accessories;
- if available interpose a quick release device (M) between the core bit spindle and the core bit (as shown in figure 5).
- before starting to drill make sure that the core bit is firmly screwed on the core bit spindle.

## Fastening the work piece and size of the work piece

- if the work object is a block and not part of a structure, fasten it in order to prevent its movement;
- prevent the work piece from shifting, moving or falling when you are cutting.

## Environmental conditions

- don't expose the machine to rain, ice or snow;
- prevent water or any other liquid from coming into contact with the electric parts of your machine;
- do not use the core drill in explosive atmospheres, for instance in presence of inflammable liquids, gas or dust. The electric core drill produces sparks which can ignite dust or smoke.

## Overhead drilling (ceiling drilling)

You can perform overhead drilling (upward) when the core drill is used in the dry mode. Overhead drilling is allowed in the wet mode ONLY if you use a proper stand and a water collecting device that avoids water coming into contact with any electrical parts. These devices are available as CARDI accessories.



**Warning:** the possible drop of the core can be dangerous. Watch out!

## Operating instructions

Follow these instructions:



**Warning:** do not touch any moving parts of your core drill when operating.

- if you want to operate in the wet mode, open the valve (the valve is open when the handle is parallel to the water stream). The water should come out from the centre of the core bit.
- if you use the core drill hand-held, using a start drilling device, begin to drill into the material, pressing lightly. Let the diamond segments drill about 1 cm deep into the material. This operation is very important because, if correctly carried out, leads to a perfect centering and makes drilling

easier. After this some start drilling devices need to be removed;

- if you use the core drill with a stand, fix the stand on the material to be drilled and then mount the core drill to the stand, according to the instructions provided by the manufacturer of the stand. Then switch on the core drill, keeping the core bit not in contact with the material to be drilled. After this operation, using the moving system of the stand, move the core drill and the rotating core bit closer to the material and, pressing lightly, drill about 1 cm into the material. This operation is very important because, if correctly carried out, leads to a perfect centering and makes drilling easier. In any case, refer to directions provided by the manufacturer of the stand;
- after the centring operation, increase the forward speed. On one hand, a too low forward speed leads to polishing of diamond sectors, decreasing their drilling capacity. On the other hand, a too high forward speed, leads to a quick segments wear.
- when drilling, make sure that the rotation axis of the core bit doesn't move and avoid any possible movement of it. When the core bit rotation axis moves, the friction between the wall of the hole and the core bit leads to a considerable power loss.
- if you can not continue drilling, you can make a new hole around the old one (over-drilling), keeping the same rotation axis. The diameter of the new hole must be at least 15-20 mm bigger than the diameter of the old one;
- drilling materials containing wood, cork, rubber, foam polystyrene can lead to problems moving forward the core bit. If you have this kind of problems, pull the core out of the hole and remove all the materials listed before that don't allow the core bit to go on and then continue with drilling operations;
- in case the electric power goes off, set the switch to the off position, preventing the machine from accidentally self starting;
- do not touch the core bit after performing a drill. The core bit can be very hot and cause severe burns.

## Mechanical clutch



**Warning:** the unexpected block of the core bit rotation can cause an heavy jerk at your arms.

The maximum force of this jerk at your arms, accordingly with the safety regulation, can not exceed 40 Kg. Be always ready to resist this kind of jerk and to quickly release the switch. Your CARDI core drill is equipped with a safety mechanical clutch that comes into operation in case of sudden stop of the core bit rotation. Despite your drill is equipped with this device, you must always be watchful and be ready to resist the jerk and release the switch. The block of the core bit rotation is dangerous for the operator

## Electronic devices

Your core drill is equipped with a CARDI multifunction electronic device that includes a soft-start and an electronic clutch.

- the soft-start allows the motor soft-start, reduces current peak that occurs when you switch the motor on, helps you when you begin drilling, allowing gradual core bit rotation and avoiding jerks at your arm, and allows you to use your core drill connected to the household electric outlet equipped with automatic switch;

- the electronic clutch cuts off power to the motor in case of excessive overload, increasing the operator safety and preventing damage to the motor. When the overload is over, the device gives back power to the motor that begins working again;
- if the electronic clutch operates frequently means that the core drill is not used properly. Possible causes can be a not suitable forward speed, an excessive friction between the core bit and hole wall or an excessive drilling depth.

### Drilling deeper than the core bit length

If you want to make a hole deeper than the core bit length proceed as follows:

- drill till the end of the core bit;
- pull the core bit out of the hole and remove the core;
- place a proper core bit extension between the core bit and the core drill thread;
- insert the core bit in the hole and proceed drilling.

## Maintenance - Service - Warranty

### Periodic maintenance

- at the end of the work, after having removed the core bit, blow compressed air inside the rotating motor in order to remove dust and powder. Do this operation wearing protective goggles;
- before starting any other cleaning, maintenance or lubrication operation make sure that the core drill is unplugged;
- keep lubricate the core-bit shaft thread;
- keep your core drill clean and dry, in particular its handles;
- never use solvents or other harsh chemicals for cleaning your core drill;
- after use put your core drill in a dry, safe and inaccessible to children place;
- gears are lubricated by lubricating oil and grease which are suited for any external temperature. You don't have to check the oil level or to fill it up.
- always unplug the core drill during check or replacement;
- never unplug the core drill by pulling the cord;
- inspect often feeding cable and extension cords, making sure that they don't have any damage like cuts, abrasions or live conductors. If you find a damage, ask a CARDI authorized service centre for replacement;
- do not use the core drill with damaged components or with malfunctions, in particular when the switch doesn't work properly. In these cases, ask a CARDI authorized service centre for replacement.

### Service

- after 250 hours of work, bring your core drill to a CARDI authorized service centre for periodical check;
- any core drill repairing must be carried out by CARDI authorized service personnel only. Ask your dealer for the list of the CARDI authorized service centres;
- your machine's serial number is stamped on the machine or printed on the data plate as shown in figure 10;
- use original CARDI spare parts only.

### Warranty

Your product is under CARDI warranty for 12 months, starting from the date of purchase. This warranty is against faulty workmanship, flaws material and design problems. The warranty covers free components replacement, manpower needed for replacement and wearing materials such as oil and lubricants if intact before the repairing operation. The warranty doesn't cover the replacement of:

- components of the product replaced or modified by people not authorized by CARDI;
- components damaged by carelessness, not suitable use or overloaded;
- components of products from which safety devices have been removed;
- worn wearing parts replaced during repair.

This warranty does not apply to products that have been damaged by carelessness like water entering the core drill, lack of periodic cleaning and maintenance, damage of the threaded components or the spindle etc.

The life of wearing parts is variable depending on the working time and the kind of work they are used for. Examples of wearing parts are: cables, switches and plugs, brushes, commutators, clutch plates, ball and roller bearing not in oil, sealing rings, transmission spindles, filters, etc.

If during repairing under warranty, a wearing part is worn and this can affect the safety and the operation of your product, the customer is asked to pay for the replacement of these components not under warranty. If the customer refuses this, no repairing operation will be carried out.

The warranty covers free replacement of components which are defective due to wrong manufacturing or assembly, if the product is brought to an authorized service centre and if:

- the product is together with a purchasing document stating when the product has been purchased. Valid purchasing documents are invoices or delivery certificates;
- maintenance operations have been carried out every 250 working hours, replacing the worn wearing parts;
- no unauthorized people have serviced the product;
- the product has not been misused and it has been used accordingly with the directions given in this user manual;
- all safety directions have been followed.

Your CARDI product is not under warranty if:

- the product has been serviced by people not authorized by CARDI.
- damage is due to incorrect use and/or carelessness. Dents due to drops or strokes will be considered evidence of carelessness;
- damage has been caused by mechanical or electrical overload;
- damage has been caused by water, mud or any other liquid entering the product.

When your product is under warranty, in some cases, for example if the CARDI authorized service personnel think the repairing is too expensive to be carried out, the free substitution of the product is possible. In addition, the substitution under warranty is provided after two fruitless reparation attempts and after the authorization of a CARDI service manager. In case of substitution, the customer is, usually, requested to pay for the worn wearing parts of the product that has been replaced.

## User-replaceable components

No components of the CARDI product can be replaced by the user. Replacement must be carried out by CARDI authorized personnel only.

## CARDI service centres - Address list

Ask your dealer for a CARDI service centres address list.

## Package contents

For the list of contents refer to the *Spare Parts List*, specific for your model, located in the package together with this manual.

**WARNING:**  
THE MANUFACTURER DECLINES ALL RESPONSABILITY  
IN CASE OF NO RESPECT OF THE ABOVE WRITTEN  
"SAFETY AND OPERATING INSTRUCTIONS".

### Disposal of the product



The symbol on the left, that you can find on the product or on its packaging indicates that this product may not be treated as household waste. At the end of its life the products must be handed over to the applicable collection point for the recycling of electrical and electronic equipment.

Be sure that this product is disposed correctly. You will help prevent potential negative consequences for the environment and human health. For more detailed information about what to do when your product doesn't work and is not fixable, contact the dealer where you did purchase the product.

Your product has been introduced new on the market after August 13<sup>th</sup> 2005.

This manual is subject to modifications without notice.











**CARDI s.r.l.**

via Leonardo da Vinci 21  
I-24030 Pontida (BG) Italia  
Tel.+39 035 795029 - Fax.+39 035 796190  
info@cardi.biz www.cardi.biz